

SERVICE MANUAL

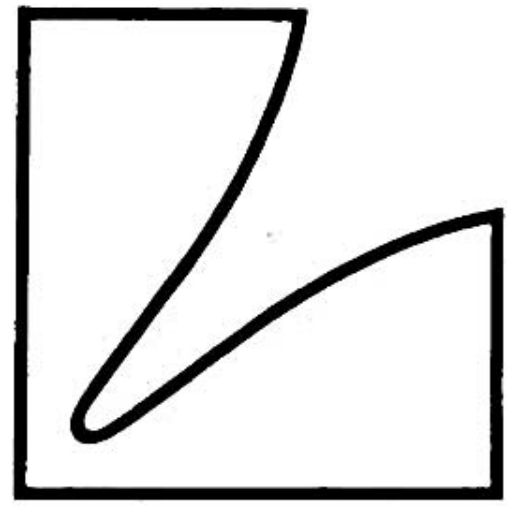

AUTOMATIC DIRECT DRIVE PLAYER SYSTEM **PD-277**



CONTENTS

EXPLANATION OF OPERATION	1
ALIGNMENT PROCEDURE	2~4
EXPLODED VIEW	5
EXPLODED VIEW PARTS LIST	6
CONTROL P.C.B. PARTS LIST	7
MOTOR P.C.B. PARTS LIST	8
SPECIFICATIONS	9
PD-277 SCHEMATIC DIAGRAM	10 · 11

EXPLANATION OF OPERATION

(1) PLAY

When the "PLAY" button is pushed, both the SCR1 and SCR2 are turned "ON".

- (a) The sub-motor starts rotating when the SCR2 is switched on, which makes the main gear rotate and the gear switch on. Therefore even if the play switch is turned off, the sub-motor keeps rotating and operating until the gear switch is turned off after one rotation.

By the rotation of sub-motor, the rotation plate is pressed to the delivering arm, and at the same time, the delivering arm starts rotating, which, in case that the tone arm is out of the arm-rest, gets the tone arm returned to the arm-rest side in the former half of rotation, then gets it conveyed to the lead-in position of the LP or EP record in the latter half of rotation. The gear switch is turned off when the gear gets one rotation, and the rotation plate gets away from the delivering arm, and the tone arm gets free for operation and keeps on playing.

- (b) When the SCR1 is turned on, the solenoid starts rotating according to the selection at speed selector, LP (33rpm) or EP (45rpm).

At the LP position, the rotating angle of the selector gets the bigger one, and the rotation of the delivering arm stops at the lead-in position of the LP, while at the EP position, the rotating angle of the selector gets the smaller one, and the rotation of the delivering arm stops at the lead-in position of EP.

When the gear starts rotating by the rotation of sub-motor, the gear switch is switched from NC side to No side, which makes the motor circuit opened between the terminal. 18 and 20, and the main motor starts rotating.

(2) AUTO PLAY

When the stylus of cartridge comes to the end of the disc grooves after the playing, the delivering arm moves rapidly between the L.E.D. and photo transistor.

When the voltage at the input terminal 3 in the operation amp. exceeds the voltage at the input terminal 2, the output of operation amp. turns to be (+), and only the SCR2 works, which makes the sub-motor get one rotation.

The pick-up arm is returned to the arm-rest in the former half of rotation of the main gear.

As the solenoid does not rotate, the selector stops at the angle corner of the rotation plate, which does not make the rotation plate rotate and the pick-up arm stops at the arm-rest.

When the pick-up arm gets back to the arm-rest, the rest switch is turned on, and the gear switch is switched to NC side, which makes the motor circuit shorted between the terminal. 18 and 20 and the main motor stops finally.

(3) REPEAT PLAY

Like the AUTO PLAY mode, the SCR2 turns on, which makes the sub-motor get one rotation.

The pick-up arm is returned to the arm-rest in the former half of rotation of the main gear.

At the same time, the SCR1 also turns on and the solenoid rotates either to the LP or EP side depending ON speed selector just as the case that PLAY switch is turned on.

The delivering arm rotates till the lead-in position of LP or EP, and repeat playing.

(4) CUT

When the cut button is pushed in, only the SCR1 works, and the solenoid does not rotate. Only the sub-motor rotates, the pick-up arm gets back to the arm-rest, and the main motor stops rotating upon its return at the AUTO mode.

(5) PU arm up-down operation

When the lifter lever gets down, the main gear stops, and the lifter cam-plate goes down, and the pick-up arm is kept in the down status, while the main gear rotates, the lifter cam-plate is lifted up by the main gear, and the pick-up arm is kept in the up status

ALIGNMENT PROCEDURE

(1) Adjustment of sensor voltage

Adjust the voltage at the test pin 10 and 12 in the control circuit as stated hereunder.

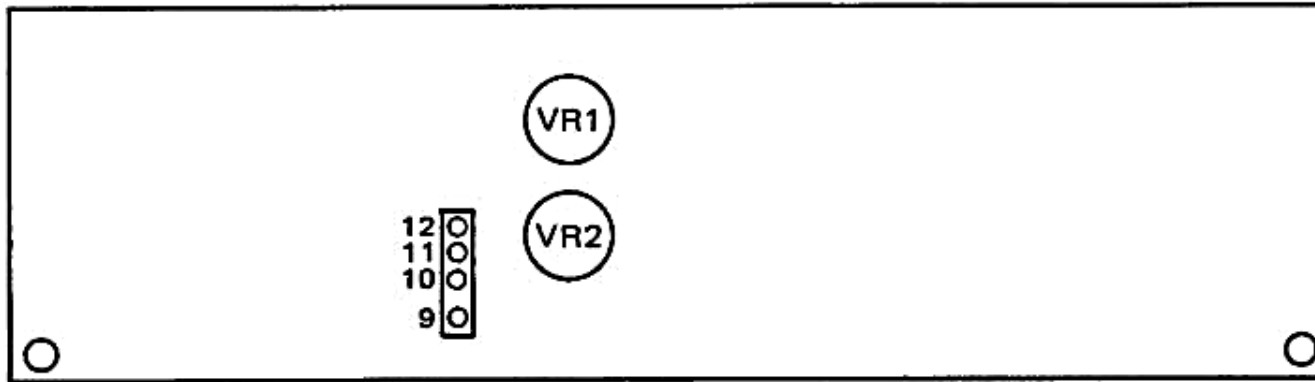

	collector voltage photo transistor	voltage at operation amp. input terminal 2
setting value	0.2V	0.5V
adjustment part	VR1	VR2
test pins measured	9 ... 10	9 ... 12
measuring condition	confirm the delivering arm does not cover the space between LED and photo transistor	confirm the speed selector is put at LP
Remarks		

(2) Adjustment of lead-in position

Set the mode at AUTO, and push on the PLAY button, then adjust the eccentric pin(1) so that the stylus position can be put in the right position. (Refer to fig. 1.)

The test record, NEC ES1008 or the equivalent shall be used.

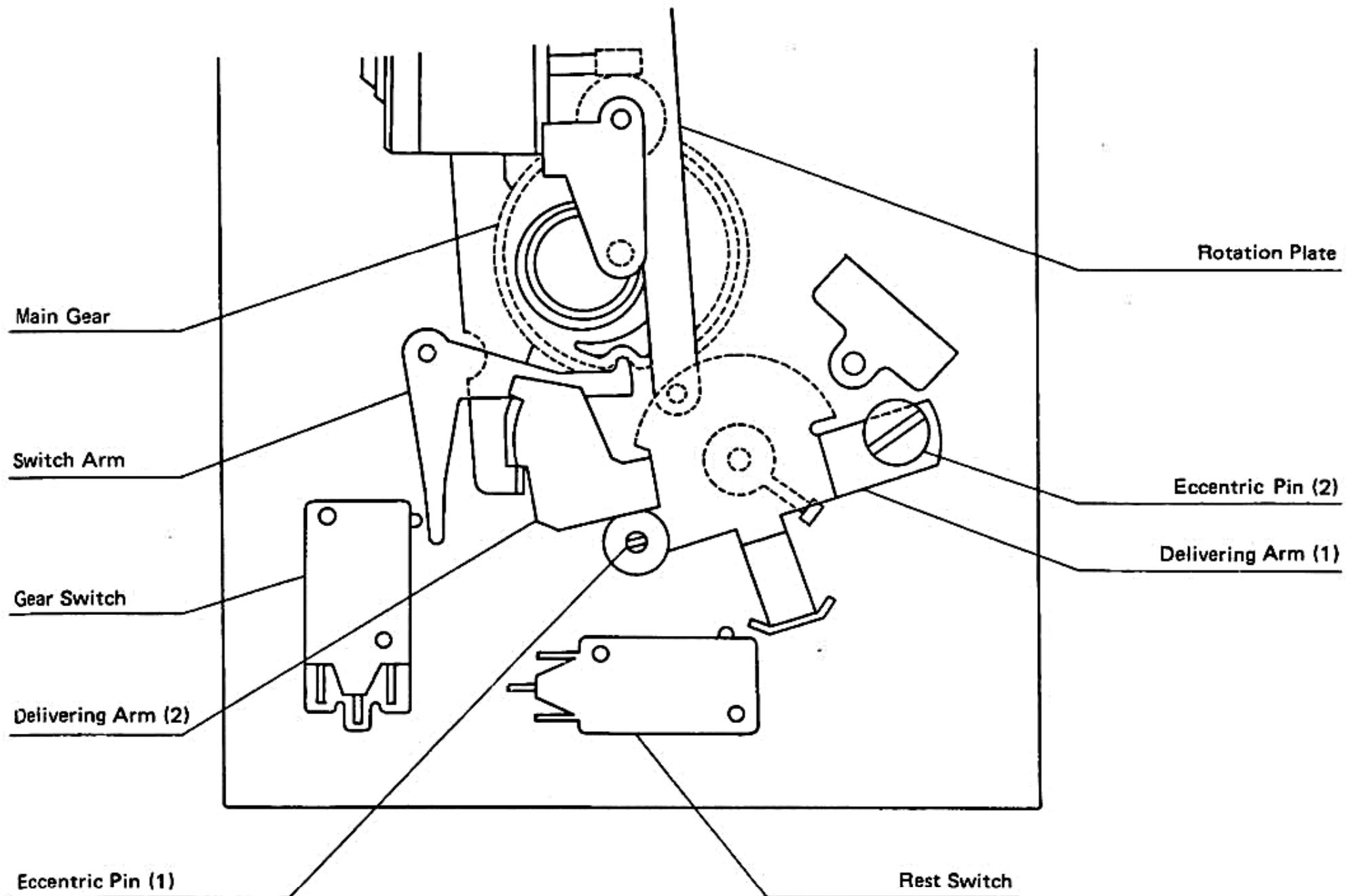

Fig. 1.

	AUTO-IN POSITION	
	LP	EP
Specification	296.2φ ... 293.2φ	171.85φ ... 168.4φ
test record count	7 ... 22	12 ... 29
Target spec	294.7φ	170.125φ
of adjustment	14.5	20
test record count		

(3) Adjustment of return position

Set the mode in AUTO, and adjust the eccentric pin (2) so that the position from the center of platter to the stylus can be put in the following range.

	AUTO RETURN POSITION
Specification	115.6φ ... 105.6φ
test record count	18 ... 23
Target spec	109.8φ
of adjustment	21
test record count	

(4) Height adjustment of elevation plate

This adjustment shall be made by the EL nut.

The elevation plate goes down by clockwise turn of EL nut, while going up by counter clockwise turn.

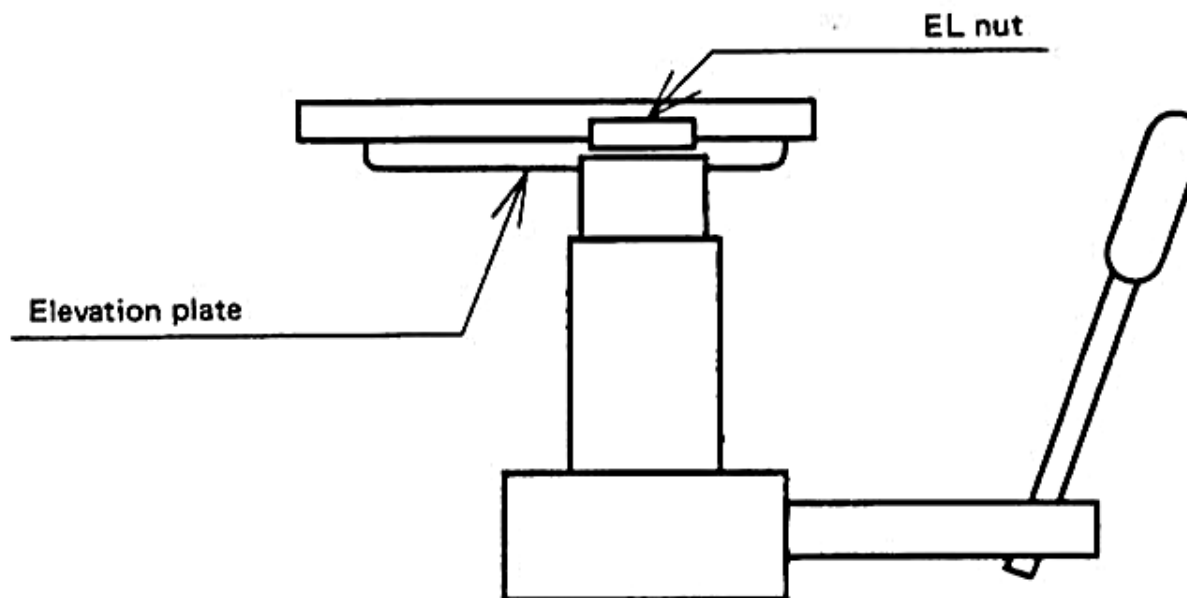

(5) Adjustment of rotation

Set the speed adjustment knob at the mechanical center position for both 33 and 45 r.p.m. respectively, and adjust the VR1 (33 r.p.m.) and VR2 (45 r.p.m.) in the motor control P.C.B. so that the stroboscope gets stationary.

(6) Wow & Flutter adjustment

Adopting the test record for wow & flutter measurement, adjust the semi-fixed resistors VR3, VR4 and VR5 in the motor control P.C.B..

As to the adjustment of wow & flutter, the wow meter is absolutely necessary.

The optimum adjustment is made at our factory and please refrain from readjustment as much as possible, since the well-practiced technique is required.

(7) The distance between delivering arm and the friction rubber at the rotation plate.

Adjust the space between the delivering and the friction rubber at the rotation plate, which is mounted to pick-up arm, to around 1.5... 2.0mm at the position of main gear.

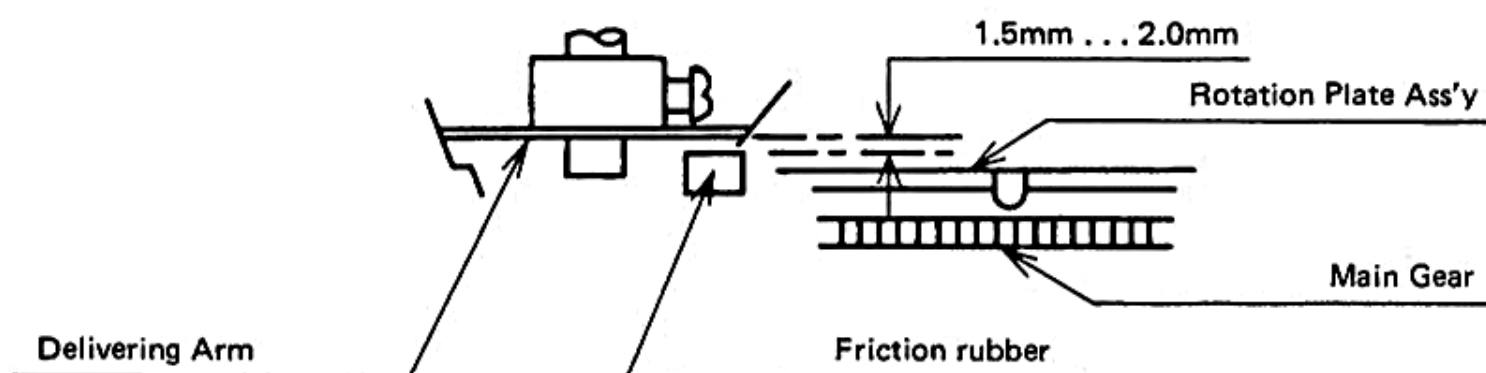

Check if the friction rubber is not damaged and it is inserted rightly, and also confirm if no oil adheres to rotation plate and friction rubber.

Among the good having the serial number up to 1500, when you found it difficult to get the pick-up arm back to arm-rest completely at return mode even after the adjustment as above mentioned, the rotation plate has to be replaced from original 896250-1 (with red mark, length; 26mm) to 896250-2 (with blue mark, length; 26.5mm).

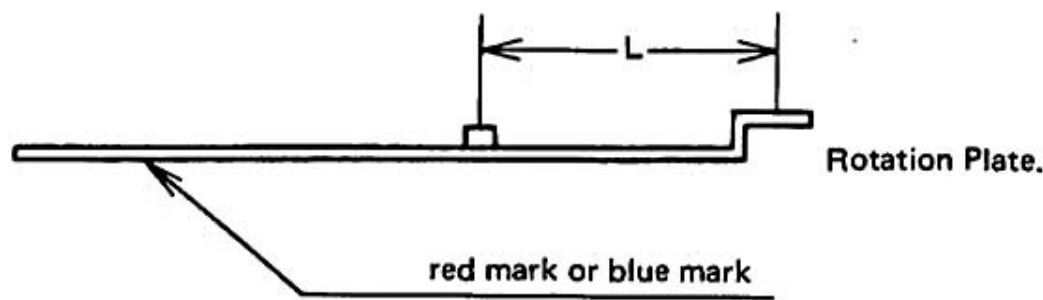

(8) The selector solenoid shall be checked if the switching operation between LP and EP is found OK under DC 12V power supply.

Also when the power is switched off, the part carved for LP and EP selection shall be put back to the range to where the select arm goes down.

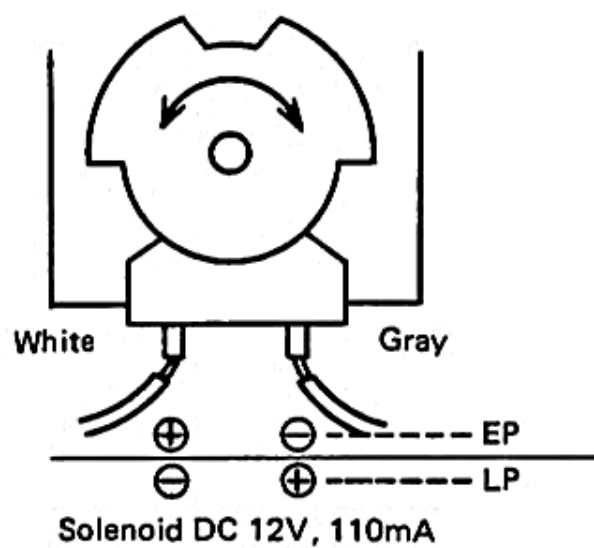

Check if such metallic materials as screw or washer does not stick to the magnet of solenoid.

(9) When the power supply having DC 5V is applied to the sub-motor (lead wire; red ⊕, white ⊖) the rotation plate, select arm and switch arm shall follow each cam surface and shall be operated without such noise as follows:-

- (a) The rattling noise caused by the something attached to gear or damaged gear.
- (b) The creaking and droning noise caused by the deep gearing.
- (c) The gear noise by the shallow gearing.

The allowance of main gear for up-down ward:	0.1 0.7 mm
The allowance of select arm for up-down ward:	0.05 0.5 mm
The allowance of R solenoid (select cam) for up-down ward:	0.2 0.8 mm
The allowance of switch arm for up-down ward:	0.1 0.7 mm

Sub-motor: DC 5V 50mA, 180mA when locked.

(10) Lubrication

The lubrication shall be made by FLOIL G.P.670 grease made by KANTO chemical or the equivalent.

The portions to be lubricated:

- (a) The axes:
 1. the axe of main gear
 2. the bearing for up and down operation of 2 stage gear.
 3. the axe of select arm
 4. the axe of rotation plate.

Caution: The lubrication is not allowed to the axe of switch arm and the select cam axe of R solenoid.

- (b) The gear:
 1. all peripheral contour of the worm gear.
 2. all peripheral contour of the large and small flat gear.
 3. all peripheral contour of the cam surface.
- (c) The lubrication is not necessary to the main motor due to its special construction.

EXPLODED VIEW

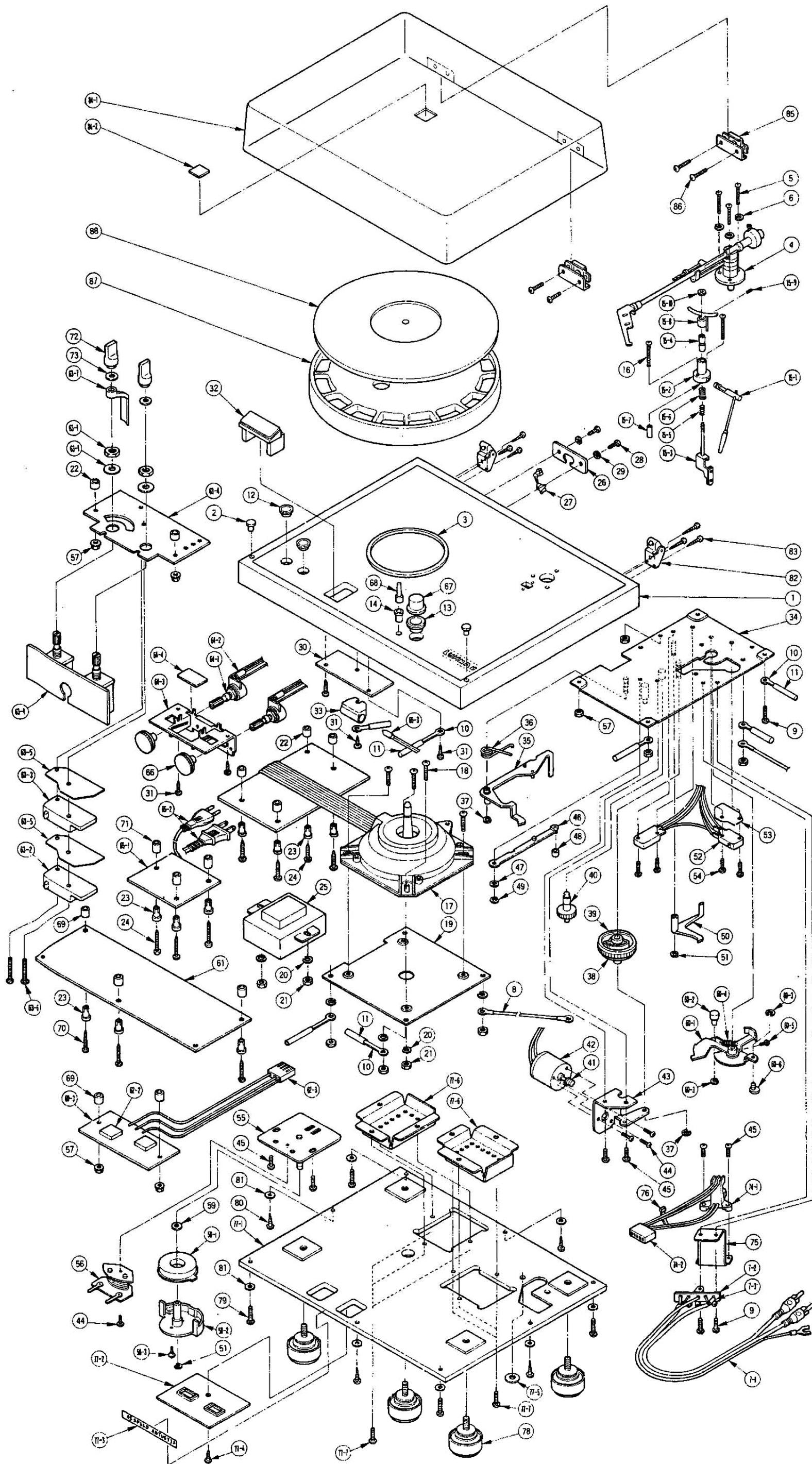

EXPLODED VIEW PARTS LIST

Remarks;
 Stock No. : Important parts in stock
 Parts No. : not in stock

SYMBOL NO.	STOCK NO.	PART NO.	DESCRIPTION	SYMBOL NO.	STOCK NO.	PART NO.	DESCRIPTION
1	WBQ0001	872144	Cabinet Ass'y	58	AYQ0002	897303-1	Magnet Ass'y (2)
2		892766	Cover Cushion	58-1		897378	Magnet Ass'y (1)
3		897134	Edge Gum	58-2		871668	Select Cam
4	WZQ0001	851716	PU Ass'y	58-3		YAC20B06	FM 2x6
5		YAC30H18	FM 3x18	59		YWA031B	W 3.1x6x0.1
6		YWC030B	SW 3φ	60	UOQ0003	896357-2	Delivering Arm Ass'y
7		895979	5P Lug Terminal Ass'y	60-1		896355-2	Delivering Arm Ass'y (1)
7-1		893699	Shield Wire Ass'y	60-2		896598-1	Eccentric Pin
7-2		890979	5P Lug Terminal	60-3		YWJ040B	EW 4φ
8		898193	Earth Wire Ass'y	60-4		801554	Arm Spring
9		YJJ30A08	EMT 3x8	60-5		YZE30B14	Hexagon Bolt 3x14
10		890755	Lug	60-6		891066-2	Eccentric Pin (2)
12	WDQ0001	897935	SP Escutcheon	61	APQ0001	872163	Control P.C.B. Ass'y
13	WDQ0002	897936	P Escutcheon	62		872172	Push Switch P.C.B. Ass'y
14	WDQ0003	897938	C Escutcheon	62-1		872146	Push Switch P.C.B.
15	WZQ0101	898109	Lifter Ass'y	62-2	APQ0002	896120	Push Switch
15-1		898108	Lifter Cam Ass'y	62-3		898197	Connector Housing Ass'y
15-2		897925	Lifter Base	63	SPQ0002	898119	Changeover Ass'y
15-3		898110	Cam Plate Ass'y	63-1		872164	Changeover Switch Ass'y
15-4		897932	Lifter Shaft	63-2		898199	Micro Switch Ass'y (1)
15-5		287680	Cam Spring	63-3		898200	Micro Switch Ass'y (2)
15-6		897926	Q Spring	63-4		897945	Switch Bracket
15-7		898111	Pin	63-5		893327	Insulation Sheet
15-8		897929	EL Plate	63-7		897937	SW Lever
15-9		YZE26B04	Hexagon Headless Screw M2.6x4	64		872187	VR Ass'y
15-10		897929	EL Nut 6φ	64-1	RVQ0001	703062	Volume 500 ohm B
16		YAC26H25	FM 2.6x25	64-2		702233-3	UL Tube 3.7x1.5
17	AMQ0001	631667-3	DD Motor DDM511M-23	64-3		871309	Mirror Holder
18		YJJ40B06	EMT 4x6	64-4	UMQ0001	896167	Reflex Plate
19		871676	Motor Holder	65-1	APQ0003	872166-1	Power Supply P.C.B. Ass'y
20		YWC0.40L	SW 4φ	65-2		BK0023	Power Cord (SG)
21		YNA040B	FLN 4φ			BK0022	Power Cord (SK, EK)
22		897342-1	Column			BK0018	Power Cord (EE.)
23		898343	Bush	65-3	ALQ0001	894001-1	Neon Lamp
24		YJC30B20	FMT 3x20	66	WJQ0001	893907	VR Mold Knob
25	PTQ0003	872118	Power Trans (240V only)	67	WJQ0002	897934	P Button
	PTQ0001	872116	Power Trans (120V only)	68	WJQ0003	897933	Cut Button
	PTQ0002	871747	Power Trans (220V only)	69		897342	Column
27		BU0033	Cord Stopper (SK, EK, EZ)	70		YJC30B16	FMT 3x16
		BU0039	Cord Stopper (SG)	71		897342-2	Column
28		YAC30H15	FM 3x15	72	WJQ0004	898201	Changeover Knob
29		YWC030A	FM 3 x 6 x 0.5t	73		898187	Himeron W
30		897237	Lamp Cover	74	ADQ0001	898203	Sensor Ass'y
31		YJC030B12	FMT 3x12	74	TDQ0001	896359	LED GL514
32	WDQ0004	898194	Strobo Escutcheon	74	TRQ0001	896360	Photo Transistor PT501A
33	WDQ0005	897657	Lamp Holder	74-1		896246	Sensor Holder
34	UZQ0001	871771-3	Mecha. Shassis Ass'y	74-2		898202	Connector Housing Ass'y
35		897288	Selecter Ass'y	75		897755	Sensor Angle
36		896358-1	Select Spring	76		894408	Sensor Fastener
37		YWJ032B	EW 3.2φ	77	WBQ0101	872151	Bottom Plate Ass'y
38		896361	Main Gear (2)	77-1		872124	Bottom Plate
39		851326	Main Gear (1)	77-2	WLQ0001	871310-1	Speed Adjustment Plate
40	UOQ0001	896243	Gear (1)	77-3		898163	SP sheel
41	UOQ0002	896244	Gear (2)	77-4		YJC30B06	FMT 3x6
42	AMQ0101	705329	DC Motor DML148Q13	77-5		895747	Adjustment Tag
43		896240	Gear Bracket	77-6	UJQ0001	892943-1	Motor Cover
44		YAC26B04	FM 2.6x4	77-7		YJJ30B10	FMT 3x10
45		YJJ30B06	FMT 3x6	78	WNQ0001	894473	Foot
46		896250	Rotation Plate	79		'YAC30B15	FM 3x15
47		YWA050U	F Washer 5x13x1	80		'YJC31B16	FMW 3.1x16
48		891452-2	Friction Gum	81		'YWA033B	FM 3.3φ x8φ x0.5
49		YWJ040A	EW 4φ	82	UZQ0101	893020-1	Hinge Plate Ass'y
50	UOQ0004	896238-1	SW Arm	83		YCG31B12	BMW 3.1x12
51		YWJ020A	EW 2φ	84	WZQ0201	871428	Dust Cover Ass'y
52	SPQ0001	898196	Micro SW Ass'y	84-1		850242-2	Dust Cover
53		893327	Insulation Sheet	84-2		893909-1	Dust Cover Name Plate
54		YAC26B14	FM 2.6x14	85	UZQ0102	893018	Lock Plate
55		897302	Sub Shassis Ass'y (2)	86		YAC30H10	FM 3x10
56	AYQ0001	897304	Spool Ass'y	87	UZ1248	620028	Turn Table
57		YNA030A	FL 3φ	88	WZ1146	871410	Turn Table Sheet

CONTROL P.C.B. (DEP-288-L61) PARTS LIST

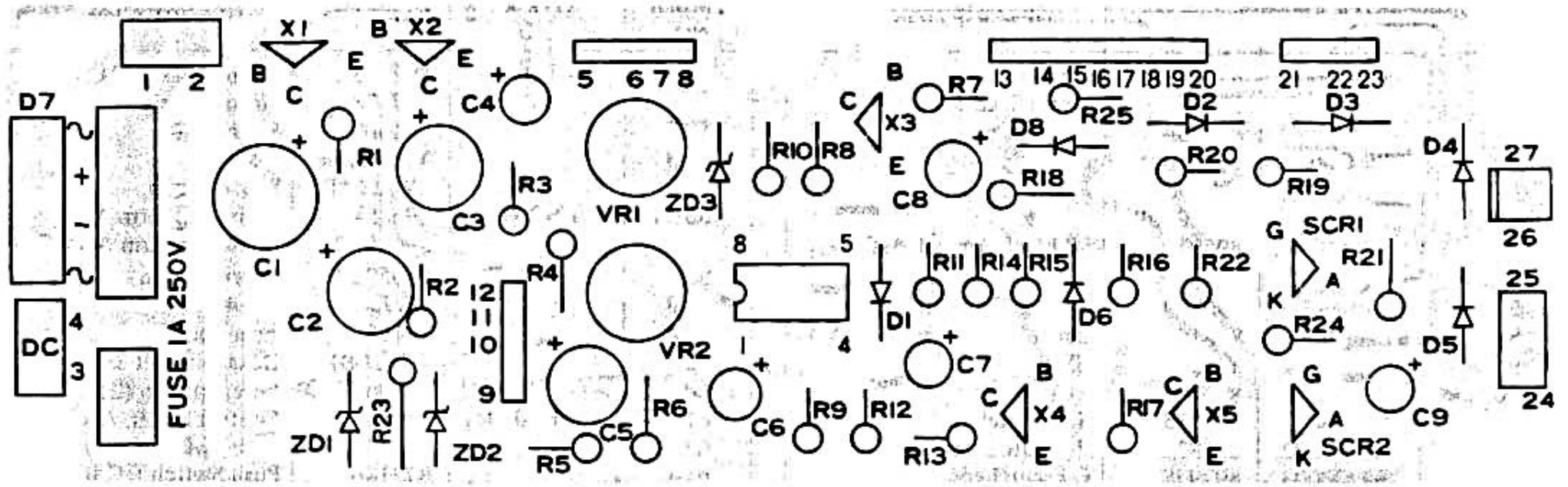

SYMBOL NO.	STOCK NO.	DESCRIPTION
[Transistor]		
X1	TR0231	2SC1061C, D
X2	TR0231	2SC1061C, D
X3	TR0029	2SC945
X4	TR0029	2SC945
X5	TR0029	2SC945
[Thyristor]		
SCR1	TFQ1001	PO5
SCR2	TFQ1001	PO5
[Zener Diode]		
ZD1	TD0128	RD13E
ZD2	TD5011	RD 5.6 EB ₂ or HZ6A-31
ZD3	TD0060	WZ061 or RD6.2EB1
[Diode]		
D1	TD5012	1S953 or 1S1588
D2	TD5012	1S953 or 1S1588
D3	TDQ0501	WO3A, B or F14C
D4	TD5012	1S953 or 1S1588
D5	TDQ0501	WO3A, B or F14C
D6	TD5012	1S953 or 1S1588
D7	TDQ0502	RB150
D8	TA5012	1S953 or 1S1588
[IC]		
IC1	TCQ0001	μPC151A or μPC741C
[Semi-Fixed Resistor]		
VR1	RT0010	SR19R 47K ohm
VR2	RT0008	SR19R 1K ohm
[Fuse]		
	BF0206 BF0075	T500mA (S) 250V 1A (U)

SYMBOL NO.	STOCK NO.	DESCRIPTION
[Resistor]		
R1	RS2001	270 2W
R2	RS0050	470 2W
R3	RC0235	330
R4	RC0075	1K
R5	RC0114	39K
R6	RC0243	560
R7	RC0278	15K
R8	RC0259	2.7K
R9	RC0100	10K
R10	RC0261	3.3K
R11	RC0124	100K
R12	RC0004	5.6K
R13	RC0100	10K
R14	RC0094	5.6K
R15	RC0100	10K
R16	RC0083	2.2K
R17	RC0100	10K
R18	RC0261	3.3K
R19	RC0263	3.9K
R20	RC0253	1.5K
R21	RC0075	1K
R22	RC0075	1K
R23	RC0261	3.3K
R24	RC0094	5.6K
R25	RC0094	5.6K
[Capacitor] (Electrolytic)		
C1	CE0089	470μF 25WV
C2	CE0050	47μF 25WV
C3	CE0050	47μF 25WV
C4	CE0074	10μF 16WV
C5	CE0085	33μF 25WV
C6	CE0098	1μF 50WV
C7	CE0074	10μF 16WV
C8	CE0074	10μF 16WV
C9	CE0074	10μF 16WV

MOTOR P.C.B. (DDM-511F-3) PARTS LIST

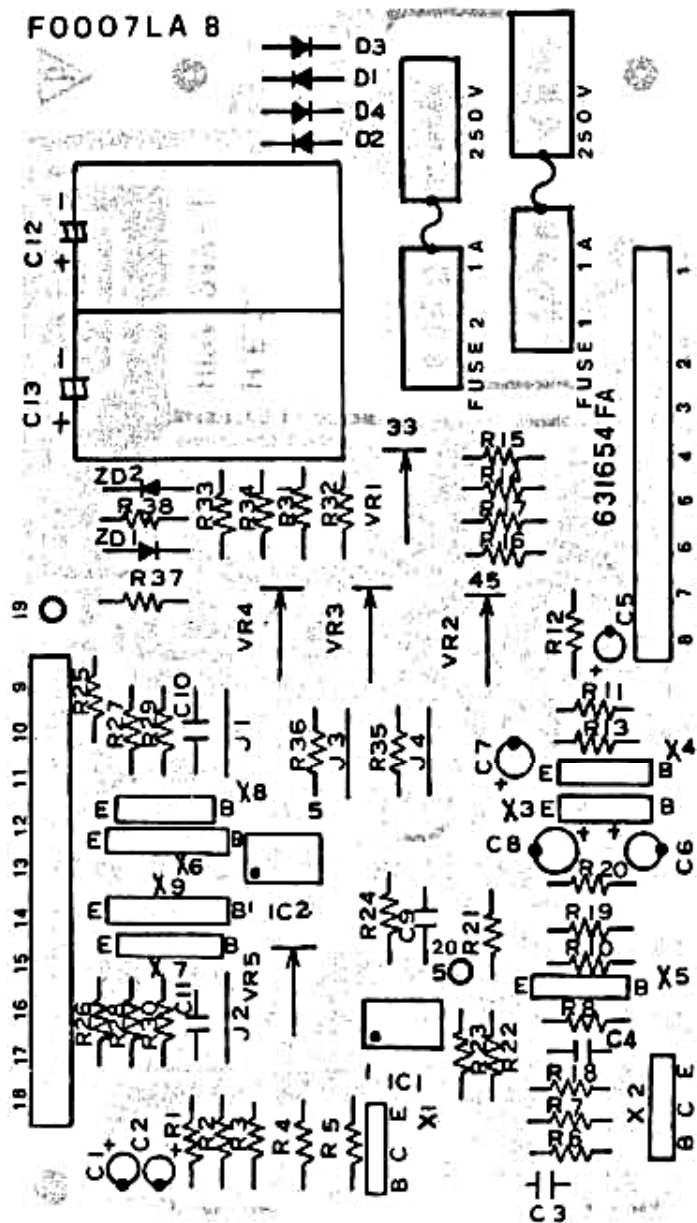

SYMBOL NO.	STOCK NO.	DESCRIPTION	REMARKS
[Transistor]			
X1	TR0029	2SC945	or 2SC1815 or 2SC2308
X2	TR0029	2SC945	or 2SC1815 or 2SC2308
X3	TR0029	2SC945	or 2SC1815 or 2SC2308
X4	TR0029	2SC945	or 2SC1815 or 2SC2308
X5	TR0043	2SA733	or 2SA844 or 2SA640 or 2SA641
X6	TR0194	2SD667	or 2SD468 or 2SD471
X7	TR0194	2SD667	pr 2SD468 or 2SD471
X8	TR0195	2SB647	or 2SB562 or 2SB564
X9	TR0195	2SB647	or 2SB562 or 2SB564
[Zener Diode]			
ZD1	TD0060	WZ061	or RD6.2EB
ZD2	TD0060	WZ061	or R6.2EB
[Silicon Diode]			
D1	TDQ0501	WO3B	or WO3C or F14C
D2	TDQ0501	WO3B	or WO3C or F14C
D3	TDQ0501	WO3B	or WO3C or F14C
D4	TDQ0501	WO3B	or WO3C or F14C
[Carbon Trimmer Potentiometer]			
VR1	RTQ0001	5K ohm B	
VR2	RTQ0001	5K ohm B	
VR3	RTQ0002	10K ohm B	
VR4	RTQ0002	10K ohm B	
VR5	RTQ0003	300 ohm B	

SYMBOL NO.	STOCK NO.	DESCRIPTION
[Resistor] (Carbon 1/4W)		
R1	RC0257	2.2K
R2	RC0231	220
R3	RC0148	1M
R4	RC0276	.12K
R5	RC0263	3.9K
R6	RC0268	5.6K
R7	RC0268	5.6K
R8	RC0320	820K
R10	RC0276	12K
R11	RC0276	12K
R12	RC0276	12K
R13	RC0314	470K
R14	RC0263	3.9K
R15	RC0268	5.6K
R16	RC0268	5.6K
R17	RC0263	3.9K
R18	RC0276	12K
R19	RC0282	22K
R20	RC0100	10K
R21	RC0263	3.9K
R22	RC0286	33K
R23	RC0286	33K
R24	RC0302	150K
R25	RC0231	220
R26	RC0231	220
R27	RC0235	330
R28	RC0235	330
R29	RC0280	18K
R30	RC0280	18K
R31	RC0100	10K
R32	RC0268	5.6K
R33	RC0100	10K
R34	RC0268	5.6K
R35	RC0235	330
R36	RC0235	330
R37	RC0075	1K
R38	RC0075	1K
[Capacitor]		
Remarks El ... Electrolytic, My ... Mylar		
C1	CE0067	33 μ F 10WV El
C2	CE0066	22 μ F 10WV El
C3	CQ0238	0.01 μ F 50WV (K) My
C4	CQ0253	0.1 μ F 50WV (K) My
C5	CE0082	1 μ F 25WV El
C6	CE0082	1 μ F 25WV El
C7	CE0082	1 μ F 25WV El
C8	CE0082	1 μ F 25WV El
C9	CQ0253	0.1 μ F 50WV (K) My
C10	CQ0253	0.1 μ F 50WV (K) My
C11	CQ0253	0.1 μ F 50WV (K) My
C12	CE0232	1000 μ F 16WV El
C13	CE0232	1000 μ F 16WV El
[Fuse]		
	BF0075	250V 1A (U)
	BF0206	250V T500mA (S)

SPECIFICATIONS

[Phono Motor Section]

*Driving System:	Direct-Drive System
*Motor:	DC-servo brushless & slotless motor
*Turntable Platter:	30 cm aluminium die-cast (weight 1.8 kgs including platter-mat)
*Rotation:	33-1/3 rpm, 45 rpm (2-speed)
*Adjustable Range of Rotation:	±4%
*S/N Ratio:	better than 60dB (IEC-B)
*Wow & Flutter:	no more than 0.03% W.R.M.S.

[Tonearm Section]

*Tonearm:	Straight Arm of static balance type
*Effective Length:	240 mm
*Tracking Error:	+2°13', -1°08'
*Overhang:	15 mm
*Cartridge Weight:	4g - 11g
*Cartridge Height:	16mm ~ 19mm (by use of spacers)
*Stylus Pressure:	0 - 3g (direct reading)
*Accessories:	Anti-skate adjustment, Tonearm Elevation

[Additional Features]

*Dust Cover:	Detachable with semi-freestop hinge
*Stroboscope:	Mirror-reflex type
*Automatic Function:	Auto-Start, Auto-Cut and Auto-Repeat

[General]

*Power Consumption:	8W
*Dimensions:	472(W) x 152(H) x 348(D) mm (18-37/64" x 6" x 13-45/64")
*Weight:	Net 10 kgs (22 lbs.) Gross: 12 kgs (26.4 lbs.)

Specifications and appearance design subject to change without notice.

PD-277 SCHEMATIC DIAGRAM

PD277 FULLY AUTOMATIC RECORD PLAYER

MOTOR CIRCUIT (DDM51M-23)

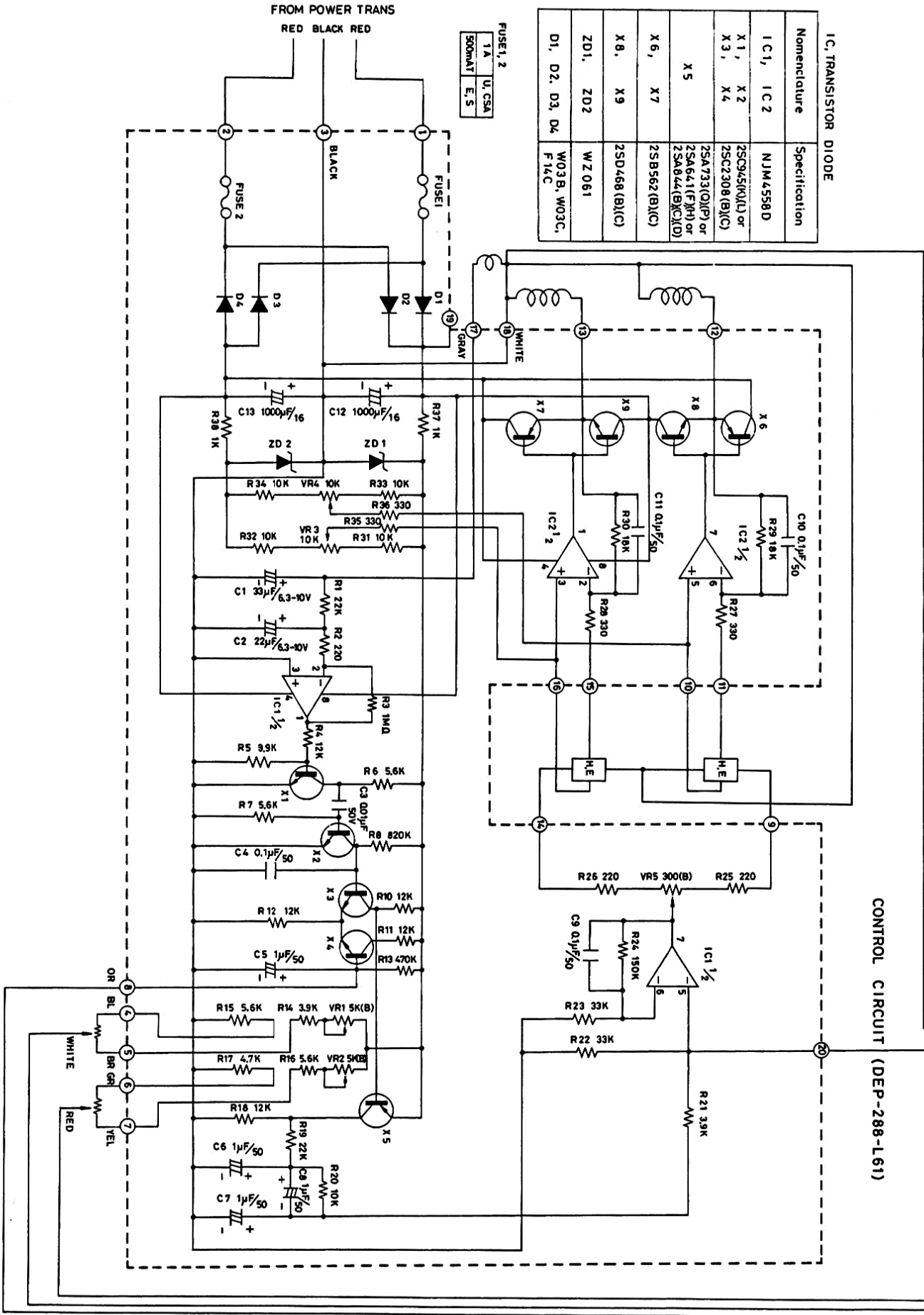

- X1, X2 : 2SC1061 (C) (D)
- X3, X4, X5 : 2SC945
- SCR1 SCR2 : P05
- IC1 : μ PC741C or μ PC151A
- ZD1 : RD1ZE (C)
- ZD2 : HZ6A-3L
- ZD3 : WZ061
- D1, D2, D4, D6, D8 : 1S953
- D3, D5 : W03A, B or F14C
- D7 : RB150
- R1, R2 : METAL OXIDE RESISTOR 2W

